



Expanseal* Putty

Hand applied polymer modified bitumen sealant

Uses

Expanchem Expanseal* Putty is recommended for sealing joints, particularly vertical and inclined joints, in most types of water retaining structures.

- Reservoirs
- Sewage disposal works
- Irrigation canals
- Sea walls
- Retaining walls (brickwork and concrete)
- Subways and basement structures
- An integral part of the waterproofing system

Advantages

- Designed for permanent immersion in water
- Tough, weather resistant seal
- Excellent slump resistance
- Easily applied by hand
- Suitable for joints up to 40 mm wide
- Resistant to bacteriological attack

Standards compliance

British Standard BS 6920:1988

Approved for use in potable water structures

Description

Expanseal* Putty thermoplastic polymer modified bitumen based putty requires heating to make it workable. On cooling it gives a slump free, flexible seal.

Expanseal* Putty is suitable for immersed joints including those where biological activity occurs.

Expanseal* Putty is suitable for sealing joints, including low movement expansion joints, in retaining walls, basements etc.

Technical support

Expanchem Fospak offers a comprehensive technical support service to specifiers, end users and contractors. It is also able to offer on-site technical assistance, an AutoCAD facility and dedicated specification assistance in locations all over the world.

Design criteria

Joint size: Expanseal* Putty may be applied to joints between 20 and 40 mm wide. In most cases it is advisable to form a sealing slot approximately square in cross-

To ensure that the sealant operates within its stated movement capacity (MAF 10% in butt joints) the sealing slot widths should be designed in accordance with the recommendations of BS 6093. The use of Primer 3 is always recommended on porous surfaces.

Where expansion joints are subject to hydrostatic head, Expanseal* Putty seals require support from a compressible filler such as Expanfill* XL

Joints in building services: Expanseal* Putty is suitable for sealing around pipe or cable entries into buildings.

Example of sealed pipe or cable entry into a building is

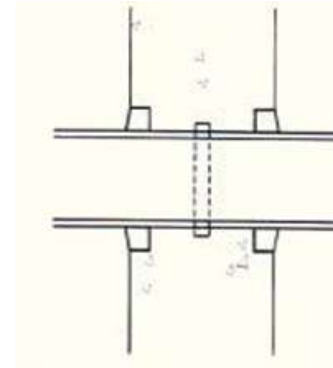

1. Expanseal* Putty
2. Expanbar* SW

Example of sealed construction joint in water retaining structure, basement, etc, is shown below

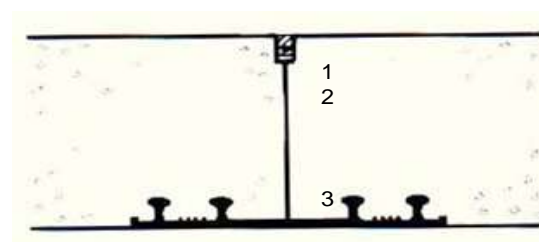

1. Expanseal* Putty
2. Bond breaker tape
3. Expanbar Rearguard 'R' waterstop*

* Also available from Expanchem



Typical properties

Solids content	: 100%
Penetration 25°C	: 70 to 90 dmm (needle)
Movement accommodation factor (BS 6093)	: 10% for butt joints
Application temperature	: 5 to 50°C (Expanseal* Putty heated to 45 to 55°C)
Biological resistance	: Expanseal* Putty is resistant to aerobic and anaerobic conditions normally occurring in sewage treatment works
Chemical resistance to occasional spillage	: Dilute acids resistant Dilute alkalis resistant Petroleum solvents non resistant Mineral oils non resistant Vegetable oils non resistant

Expanprime 3

Application temperature	: 5 to 50°C
Drying time	: 1 to 4 hour @ 25°C

Specification

Joints shall be sealed, where designated, using Expanseal* Putty, bitumen putty manufactured and supplied by Expanchem International. The material shall be applied strictly in accordance with the manufacturer's current technical data sheet.

Instructions for use

Expanseal* Putty is applied by hand after it has been heated. Tins of Expanseal* Putty must be heated in boiling water or field ovens, not by direct heat.

Joint preparation

Ensure that the joint surfaces are completely dry, clean and frost-free. Remove all dirt, dust, laitance and loose material by rigorous wire brushing. Remove all rust, scale and protective lacquers from metal surfaces. Remove any oil or grease with Expanchem Solvent 102. In expansion joints, Expanseal* Putty must always be supported by a firm backing which allows free movement. Where a particularly neat finish is required, cover face edges of joint with masking tape before priming and remove immediately after sealing work is completed.

Heating

Tins of Expanseal* Putty are heated to 45 to 55°C by placing in a field oven or in boiling water for approximately 1 hour. When using water, the water level should only come almost to the top of the tin (leave the lid on). Expanseal* Putty must not be subjected to direct heating.

Priming**Porous surfaces**

On concrete, stone, brickwork and timber, Primer 3 is required. The applied primer should be touch dry before sealing.

Non-porous surfaces

Primer not normally required. Ferrous metals should be treated with an anti-corrosion primer.

Application

Take a convenient quantity of material from the tin and mould by hand into a strip. While still hot, push this well down into the cavity to fill all crevices, ensuring good contact with the sides and base of the joint. If necessary caulk home with a piece of damp wood.

Note: If there is honeycombed concrete in the immediate vicinity of the joint, there is the risk that water under pressure may percolate behind the seal and pass into the joint. In such cases, prime the area concerned and apply additional sealant, working well into all cavities to give a 'mushroom' finish. Joints subject to flowing water should be finished flush or slightly concave.

Finishing

Heat a stripping knife and, working along the joint, cut away excess material to present a neat finish. In cold weather a gas blow torch may be run down the seal before trimming. Expanseal* Putty requires no special tools, but the use of a caulking iron is recommended for easy consolidation and to give a neat finish to the seal. Normally Expanseal* Putty will be finished flush.

Cleaning

Clean up equipment immediately after use with Expanchem Solvent 102, white spirit or paraffin. Care should be exercised in the use of solvents. Appropriate precautions should be taken. For Expanchem Solvent 102, refer to Expanchem's Health and Safety data sheet.



CONSTRUCTION CHEMISTRY

Maintenance

No special requirements. Any damage should be made good as and when it occurs.

Estimating

Supply

Expanseal* Putty	:	5 litre tins
Expanprime* 3	:	5 litre pack

Larger sized packing can be supplied to special minimum order.

Guide of Expanseal* Putty quantities

Joint size in mm	Litre per metre	Metre per 5 litre	Joint size in mm	Litre per metre	Metre per 5 litre
20 x 20	0.40	13.0	30 x 50	1.50	3.3
25	0.50	10.0	35 x 25	0.88	5.7
30	0.60	8.3	30	1.10	4.8
25 x 20	0.50	10.0	40	1.40	3.6
25	0.63	8.0	50	1.60	2.9
30	0.75	6.7	40 x 25	1.00	5.0
40	1.00	5.0	30	1.20	4.2
30 x 250.75	6.7	50	2.00	2.5	40
1.204.2					

Primer coverage:

500ml of Expanprime* 3 is sufficient for approximately 2 x 5 litre tins of Expanseal* Putty.

Storage

Expanseal* Putty has a 2 year shelf life when stored in cool dry conditions in unopened original containers.

When stored in cold stores Expanprime* 3 will have a shelf life of 12 months.

Precautions

Health and safety

There are no health hazards associated with Expanseal* Putty in normal use, however, prolonged skin contact should be avoided.

Remove Expanseal* Putty from the hands with 'Keroclene 22', 'Swarfega' or similar industrial hand cleanser.

Primer 3 and Solvent 102 should not come in contact with the skin and eyes, or be swallowed. Ensure adequate ventilation and avoid inhalation of vapours. Wear suitable protective clothing, gloves and eye protection.

In case of contact with skin, rinse with plenty of clean water, then cleanse with soap and water. Do not use solvent. In case of contact with eyes, rinse immediately with plenty of clean water and seek medical advice. If swallowed seek medical attention immediately - do not induce vomiting.

Fire

Primer 3 is a highly flammable, and Solvent 102 is also flammable. Keep away from sources of ignition. No smoking. In the event of fire extinguish with CO2 or foam. Do not use a water jet.

Flash points

Expanprime* 3	:	-1°C
Expanchem Solvent 102	:	33°C

For additional information see relevant Material Safety Data Sheet.

Additional Information

Expanchem manufactures a wide range of complementary products which include :

- waterproofing membranes & waterstops
- joint sealants & filler boards
- cementitious & epoxy grouts
- specialised flooring materials

Expanchem additionally offers a comprehensive package of products specifically designed for the repair and refurbishment of damaged concrete. Expanchem's 'Systematic Approach' to concrete repair features the following :

- hand-placed repair mortars
- spray grade repair mortars
- fluid micro-concretes
- chemically resistant epoxy mortars
- anti-carbonation/anti-chloride protective coatings
- chemical and abrasion resistant coatings

For further information on any of the above, please consult your local Expanchem office - as below.



CONSTRUCTION CHEMISTRY

* Denotes the trademark registered.

REGIONAL SALES OFFICES IN PAKISTAN:

Fospak (Pvt) Ltd.

Head Office

702, Business Avenue,
Block-6, PECHS., Shahr-e-Faisal,
Karachi, Pakistan.

Tel # +92-21-34528477, 34529859

Fax # +92-21-34522436

Email : info.khi@fospak.com.pk

Lahore Sales Office

2nd Floor Sarwar Shaheed Plaza,
Cavalry Ground,
Main Boulevard, Lahore Cantt,
Lahore, Pakistan.

Tel # +92-42-36675773

Fax # +92-42-36675838

Email : info.lhr@fospak.com.pk

Rawalpindi Sales Office

1st Floor,
Al-Harmin Plaza,
Main Murree Road,
Rawalpindi, Pakistan.

Tel # +92-51-9290592

Fax # +92-51-9290590

Email : info.isb@fospak.com.pk

Important note

Expanchem Fospak products are guaranteed against defective materials and manufacture and are sold subject to its standard terms and conditions of sale, copies of which may be obtained on request. Whilst Expanchem Fospak endeavours to ensure that the technical information on this data sheet is correct at the time of printing, it is the customer's responsibility to satisfy himself, by checking with the company that this information is still current at the time of use, that the product is suitable for the intended application, and that the actual conditions of use are in accordance with those recommended. Because Expanchem Fospak has no control over the conditions of use of its products, all recommendations or suggestions regarding the use of these products are made without guarantee.

www.fospak.com